

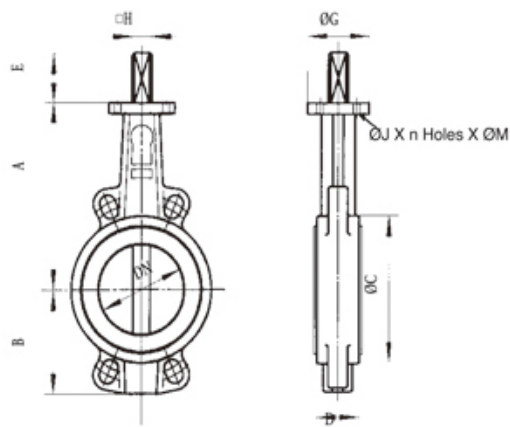

AFA[®]

WAFER & LUG TYPE BUTTERFLY VALVE
BARE SHAFT – OVERALL DIMENSION



WAFER TYPE

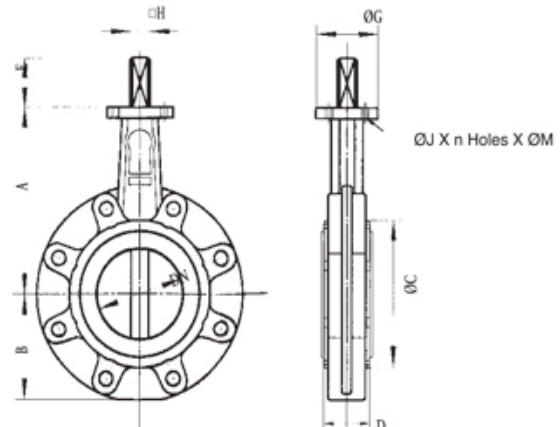

FULL LUG TYPE

NOMINAL PIPE SIZE (DN)		A	B	ØC	D	ØG	E	ØH	ØF	Actuator Flange comply to ISO 5211	
MM	INS	MM	MM	MM	MM	MM	MM	MM	MM	ØJ	ØM
25	1	121	53	65	33	65	32	7 x 7	-	50	4 x Ø7
32	1 1/4	121	57	73	33	65	32	7 x 7	-	50	4 x Ø7
40	1 1/2	130	61	82	33	65	32	9 x 9	-	50	4 x Ø7
50	2	136.5	77	90	43	65	32	9 x 9	-	50	4 x Ø7
65	2 1/2	142	87.5	103	46	65	32	9 x 9	-	50	4 x Ø7
80	3	158	95	120	46	65	32	9 x 9	-	50	4 x Ø7
100	4	180	107	152	52	65	32	11 x 11	-	50	4 x Ø7
125	5	192	121.5	180	56	90	42	14 x 14	-	70	4 x Ø9
150	6	215	144	207	56	90	42	14 x 14	-	70	4 x Ø9
200	8	241.5	171	260	60	125	36	17 x 17	-	102	4 x Ø11
250	10	280	205	315	68	150	38	22 x 22	-	125	4 x Ø13
300	12	310	235	370	78	150	38	27 x 27	-	125	4 x Ø13
350	14	367	266	418	78	150	45	27 x 27	-	125	4 x Ø14
400	16	394	324	470	102	150	50	27 x 27	-	125	4 x Ø14
450	18	419	341	525	114	210	50	30 x 30	-	165	4 x Ø22
500	20	474	374	570	127	210	65	36 x 36	-	165	4 x Ø22
600	24	565	478	697	154	210	70	46 x 46	-	165	4 x Ø22
700	28	624	520	800	165	300	80	-	63.35	254	8 x Ø18
750	30	660	539	850.9	167	300	80	-	63.35	254	8 x Ø18
800	32	672	591	906	188	300	80	-	63.35	254	8 x Ø18
900	36	720	656	1015	203	300	118	-	75	254	8 x Ø18
1000	40	800	721	1134	216	300	142	-	85	254	8 x Ø18
1200	48	940	860	1331	276	350	150	-	105	298	8 x Ø22



- DN700 to DN1000, we offer Wafer and Flange Type Butterfly valve
- DN700 and above shaft head (ØH) change round shape with key (ØF)

MAXIMUM DESIGN PRESSURE

NOMINAL PIPE SIZE	40 TO 300	350 TO 1000
MAXIMUM DESIGN PRESSURE (BAR)	16	10

MAXIMUM DESIGN TEMPERATURE

MATERIAL	EPDM	BUNA-N	HYPALON	VITON®	PTFE
TEMPERATURE RATING °C	-15 TO 130	-10 TO 80	-15 TO 135	-15 TO 135	-10 TO 80*

* Depending on backing elastomer and operating pressure

- Face to Face : API 609, ISO 5752, BS 5155 (Short), DIN 3202 (K1)
- Testing Requirement (API 598)
 - Sealing test : P.NX1.1
 - Body test : P.NX1.5

General Description

AFA butterfly valves are available for wafer type and lug type with the operation of hand lever, worm gear, electric actuator and pneumatic actuator.

These valves are designed for installation between flanges drilled in accordance with DIN, ANSI, JIS & BS and with the actuator flange comply to ISO 5211.

AFA butterfly valve's liner and disc are replaceable and available in various materials for media compatibles.

AFA butterfly valve are suitable for use with water, warm water, hot water, sea water, air, steam, gas and oil. Typical application include HVAC, petrochemical processing, oil & gas process, shipbuilding and offshore, fire fighting and sanitary system, food industries, etc.

A New Era In Total Solution