

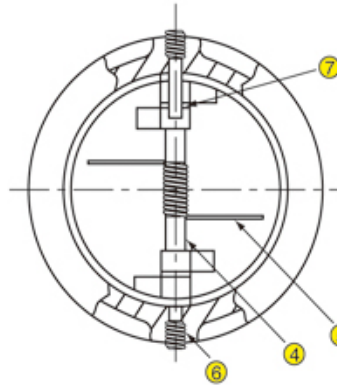

AFA[®]

FIG 977 DUAL FLAP WAFER CHECK VALVE
TECHNICAL SPECIFICATION AND DIMENSION

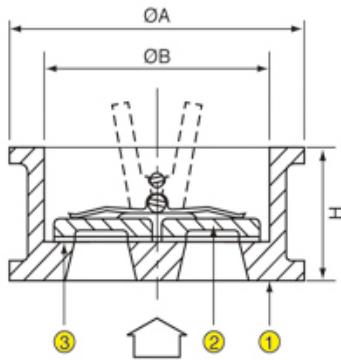

S/NO	PART NAME	MATERIAL
1	Body	Cast Iron (GG 25), Ductile Iron (GGG40)
2	Disc	AISI 316/Bronze/Ductile Iron
3	Resilient Seat	EPDM
4	Hinge Pin	Stainless Steel
5	Spring	Stainless Steel
6	Retainer Screw	Carbon Steel
7	Disc Bearing	Teflon

Other materials except above are available on request.

***Applicable Fluids** : Water, Warm Water,
Sea Water, Air & Weak Acid

Flanges Standard : DIN PN10/16

NOMINAL PIPE SIZE		EXTERNAL DIAMETER OA	INTERNAL DIAMETER OB	FACE TO FACE	MAXIMUM WORKING PRESSURE	MAXIMUM WORKING TEMP.
		DIN STANDARD		H		
MM	INS	MM	MM	MM	BAR (10°C)	°C
50	2	109	70.5	54	16	110
65	2 1/2	129	83.5	54	16	110
80	3	144	91.5	57	16	110
100	4	164	115.5	64	16	110
125	5	194	142.5	70	16	110
150	6	220	169.5	76	16	110
200	8	275	220.5	95	16	110
250	10	330	275.5	108	16	110
300	12	380	325.5	143	16	110
350	14	440	356	184	10	110
400	16	491	406	191	10	110
450	18	541	468	203	10	110
500	20	596	515	213	10	110
600	24	697	617	222	10	110

Other flanges standard i.e. ANSI, JIS & BS are available on your request.



NOTES

- Valve working under higher temperature, the pressure rating is reduced accordingly.
- Lifting eye bolt is fitted for size DN200 & above.
- * For other kinds of applicable fluids except the above, to which the check valve becomes applicable, please kindly consult your supplier or manufacturer.

